



CROSS ARM POLE EXTENSION KIT

#CAK40-#CAK50-#CAK60

12"Ext - 18"Ext - 24"Ext

(PATENTED)

Structural Reinforcements

www.polelifesystems.com

DESIGNED TO FIT ALL CROSS-ARM POLES.
PROVIDES STRUCTURAL STRENGTH TO RAISE YOUR
YOUR CROSS ARM OR REBUILD THE CROSS ARM
12" – 18" – 24" HIGHER THAN THE CURRENT POSITION

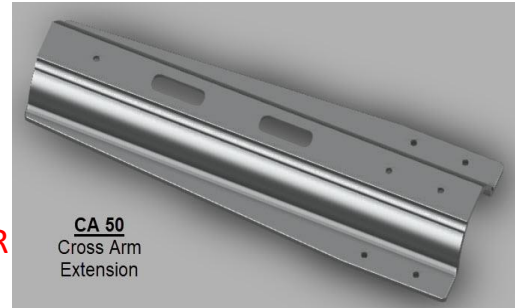

CA 50
Cross Arm
Extension

Horizontal Construction – Our simple, extremely sturdy cross arm extension system will storm harden and structurally reinforce your aging distribution/transmission facilities. This will save on requiring a complete pole replacement.

Product Details: Material is plated 10-gauge 1/8" galvanized steel, corrosion free, low cost and structurally rated to 5,000 lbs. Kit Includes: (1) Steel Extension Product

Hardware not included, compatible to all utility hardware and specifications.

ANSI Tested Strength: Vertical 5,000 LBS, Longitudinal 5,000 LBS, Transverse 5,000 LBS

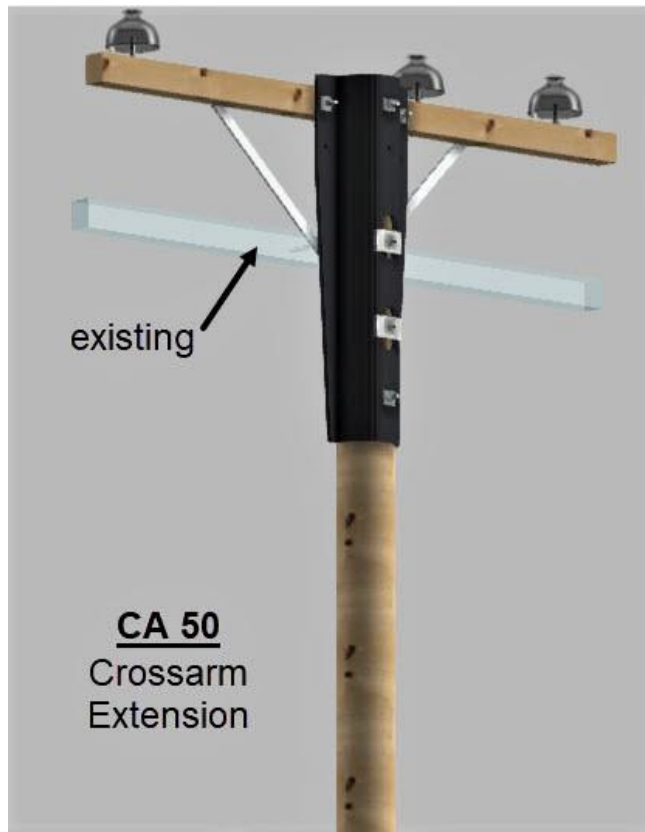

CA 50
Crossarm
Extension

